

# G80 WELD ON LIFTING POINT

## SPECIFICATION FOR 1 TON TO 15 TON

### G80 Weld on Point/Lifting Lugs

Austlift WP type weld on lifting points can be welded on any carbon steel surface as a lifting point, or to be used as a fixed anchor point for spreader beam attachment. Can also be used as an anchor point for load restraint applications.

- Marked with chain size, batch number, grade, WLL, Austlift branded with manufacture quality mark.
- Batch tested, test certificates available upon request.
- Welding instructions supplied with each unit.
- Fatigue tested > 20,000 times.



### Weld on Point (Type WP)

WLL (T)	CODE	Wt. (kg)	DIMENSIONS (mm)				
			B	D	C	C1	W
1	104001	0.55	55	14	35	95.7	50
3	104003	0.9	64	17	50	99	58
5	104005	1.8	70	22	70	137	64
8	104008	2.5	69	26.5	86	144	66.5

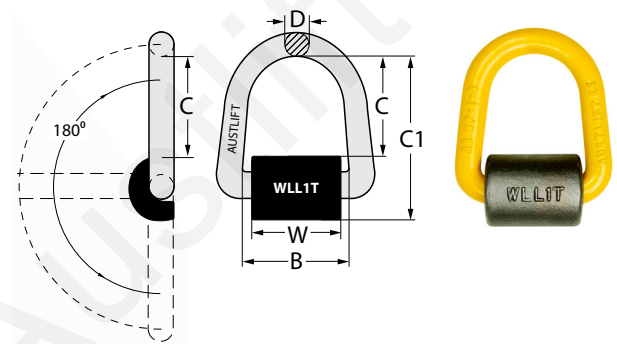

### Weld on Point Compact (Type WPC)

WLL (T)	CODE	Wt. (kg)	DIMENSIONS (mm)				
			B	D	C	C1	W
1	103901	0.4	40	13	40.5	70.5	37
2	103902	0.48	42	14	48.5	81.5	40
4	103904	0.69	46	17	49	84	42.5
6	103906	1.5	55	22	57	104.5	51
9	103909	2.5	70	26	67.5	124.5	66
15	103915	5.79	98	34	94	155	90

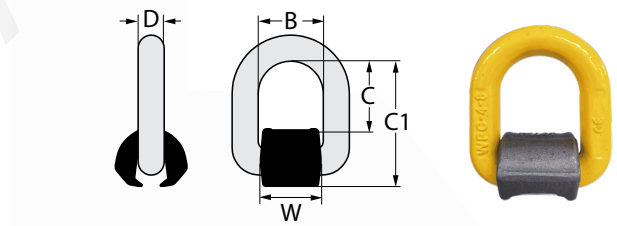

### Working Load Limit for Weld on Point (Metric)

LOADING METHOD	1		2		2		3 or 4		3 or 4	
	0°	90°	0°	90°	SYMMETRIC		SYMMETRIC		ASYMMETRIC	
INCLINATION	0°		90°		0°-45°	45°-60°	0°-45°	45°-60°	ASYMMETRIC	
SAFETY FACTOR	4		4		4	4	4	4	4	
WORKING LOAD LIMIT	WLL (T)	WLL (T)	WLL (T)	WLL (T)	WLL (T)	WLL (T)	WLL (T)	WLL (T)	WLL (T)	
LOAD FACTOR	1.0	1.0	2.0	2.0	1.4	1.0	2.1	1.5	1.0	
1	1.0	1.0	2.0	2.0	1.4	1.0	2.1	1.5	1.0	
2	2.0	2.0	4.0	4.0	2.8	2.0	4.2	3.0	2.0	
3	3.0	3.0	6.0	6.0	4.2	3.0	6.3	4.5	3.0	
4	4.0	4.0	8.0	8.0	5.6	4.0	8.4	6.0	4.0	
5	5.0	5.0	10.0	10.0	7.0	5.0	10.5	7.5	5.0	
6	6.0	6.0	12.0	12.0	8.4	6.0	12.6	9.0	6.0	
8	8.0	8.0	16.0	16.0	11.2	8.0	16.8	12.0	8.0	
9	9.0	9.0	18.0	18.0	12.6	9.0	18.9	13.5	9.0	
15	15.0	15.0	30.0	30.0	21.0	15.0	31.5	22.5	15.0	

AUSSLIFT Lifting your business to a higher level.

**NSW Head Office**

📍 43 Frank Street  
 Wetherill Park, NSW 2164  
 ☎ 02 9757 2277

**WA Office**

📍 42 Mulgal Road  
 Malaga, WA 6090  
 ☎ 08 9248 6674

**QLD Office**

📍 7 Durbell Street  
 Acacia Ridge, QLD 4110  
 ☎ 07 3272 0777

**VIC Office**

📍 475 Doherty Road  
 Truganina, VIC 3029  
 ☎ 03 9314 5525