

AUSTRALIAN LIFTING CENTRE PTY LTD

STEEL WIRE ROPE FITTINGS



AUSTLIFT®

1300 100 120
WWW.AUSTLIFT.COM.AU



LIFTING YOUR BUSINESS TO A HIGHER LEVEL



Contents

<i>Heavy Duty Commercial Wire Rope Grip</i>	95
<i>Double Throated Wire Rope Grip</i>	95
<i>Australian Standard Wire Rope Grip</i>	96
<i>Commercial Thimble</i>	96
<i>AS Gold Tip Thimble</i>	97
<i>Thimble Eye Nut</i>	97
<i>Solid Thimble Pilot Hole (Hot dip Gal)</i>	98
<i>Pre-drilled Solid Thimble</i>	98
<i>Wedge Socket, Open Type, Clevis</i>	99
<i>AS Open Thimbles</i>	99
<i>Copper Ferrules</i>	100
<i>Nickel Plated Copper Ferrules</i>	100
<i>Aluminium Ferrules</i>	101
<i>Ferrules Selection Chart</i>	102
<i>Warning</i>	102
<i>How To Use Wire Rope Grips</i>	103
<i>Wedge Socket Safety Installation</i>	105
<i>Safety Information For Wedge Socket</i>	105



Wire Rope Grips

Correctly applied Wire Rope Grips serve as a simple mechanical means of securing the end of steel Wire Rope. They are appropriate for temporarily securing the end of steel Wire Rope that may need to be shortened. They should not be used to secure a rope that is later to be lengthened from the gripped end.

Wire Rope Grips should not be used in lifting applications or rope terminations on load suspension devices that are used for lifting.

Wire Rope Grips should not be used for making terminations on live running ropes nor where a rope is required to support persons or suspended loads.

Types of Wire Rope Grips

AS Wire Rope Grips: Not for lifting applications. Manufactured to AS2076, not to be used on living running ropes, supporting persons or suspending loads. The bridge of the grip shall be marked with the nominal size. Tested Wire Rope Grips are used for applications where Socketing or splicing is not feasible for temporary or non-permanent applications. Wire Rope Grips can be used in guying applications.

Commercial Grade Wire Rope Grips Not for lifting applications. Manufactured to duty applications. Usually supplied in electroplated finish.

Stainless Steel Wire Rope Grips Not to be used for lifting. These grips are not produced to any standard.

Double Base Wire Rope Grips are commonly used for a higher grip hold of the Wire Rope. Also with the double base the grip tends not to damage the wire in case it require lengthening.

Mechanical Type Wire Rope Slices

Many Wire Rope Slings are now spliced by one of several types of mechanical splices, which mainly fall into two methods:

- Swaged aluminium alloy splices
- Swaged or pressed steel collar splices

Swaged Aluminium Alloy Splices

The rope is cut and passed through the unpressed elliptical shaped fitting. An eye is formed and the "dead end" of the rope pushed back into fitting so that it lays parallel and against the main part of the rope. The aluminium alloy fitting is then put into special dies and pressed. This procedure requires fittings of this type to be carried out in the following manner:

Whipping is to be confined to non-performed ropes only and shall be of annealed wire of the smallest gauge practical and its length shall not exceed one-half of the diameter of the rope being spliced.

The completed splice on all rope 5mm diameter and above is to be stamped with the identification mark of the company manufacturing the splice.

On all parallel fittings the "dead end" of the rope must protrude past the end of the fitting after pressing.

It is essential that all fittings used for these splices be obtained from the distributing company which holds the acceptance from this department.

Under no circumstance should substitute fittings or dies be used.

Swaged or Pressed Steel Collar Splices

This type of splice is only carried out on six strand preformed Wire Rope. The strands of the rope are unlayed and reformed to form a Flemish eye.

The steel collars are then swaged or pressed over the ends of the strands to prevent them from unlaying.



COMMERCIAL GRADE WIRE ROPE GRIPS

Heavy Duty Commercial Wire Rope Grip



WARNING NOT FOR LIFTING PURPOSES

- Only genuine Austlift grips have a Gold U-BOLT for instant recognition.
- Heavy duty saddle and comes with larger nut size for greater tightening force.
- Sizes available are from 2mm to 25mm.
- Zinc plated finish on both U-bolt and saddle.
- Tolerances may vary for commercial products
- NOT FOR LIFTING PURPOSES.

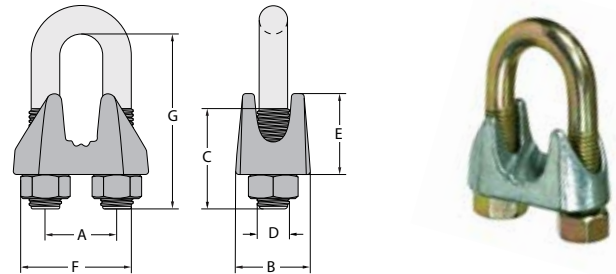

CODE	SIZE		Wt. kg/pc	DIMENSIONS						
	in	mm		A mm	B mm	C mm	D in	E mm	F mm	G mm
301002	1/16	1.6-2	0.014	9.5	12	12.5	3/16	10	20.5	18.5
301003	1/8	3	0.017	11	14	14	3/16	10.8	22	20
301005	3/16	4-5	0.03	14.5	15	16.5	1/4	13	26	24
301006	1/4	6	0.053	17	18.5	20	5/16	15	32	31.5
301008	5/16	8	0.06	18.3	20	22	5/16	16	35	34
301010	3/8	9-10	0.103	22.5	22	27	3/8	22	40.5	41.8
301013	1/2	12-13	0.21	27	26	33	7/16	23.3	49	51
301014	9/16	14	0.23	30	27.5	35	1/2	26	54	54
301016	5/8	16	0.25	32.5	28.5	40	1/2	28	57.5	59
301020	3/4	19-20	0.37	34.5	30	42	9/16	32	59.5	68.5
301022	7/8	22	0.5	41	35	46	5/8	37	69	78
301025	1	25	0.6	45.5	38	55	5/8	41	75	87.5



WARNING NOT FOR LIFTING PURPOSES

- Only genuine Austlift grips have a Gold U-BOLT for instant recognition.
- Heavy duty double saddle and comes with larger nut size for greater tightening force.
- Sizes available are from 8mm to 16mm.
- Zinc plated finish on both U-bolt and saddle.
- Designed and tested according to AS2076
- NOT FOR LIFTING PURPOSES.

Double Throated Wire Rope Grip

CODE	SIZE	DIMENSIONS						
		A mm	B mm	C mm	D mm	E mm	F mm	G mm
301608	8	9	11	46	27	85	39	M8
301612	10-12	12	14	51	30	90	40	M10
301616	16	17	19	53	32	95	46	M10

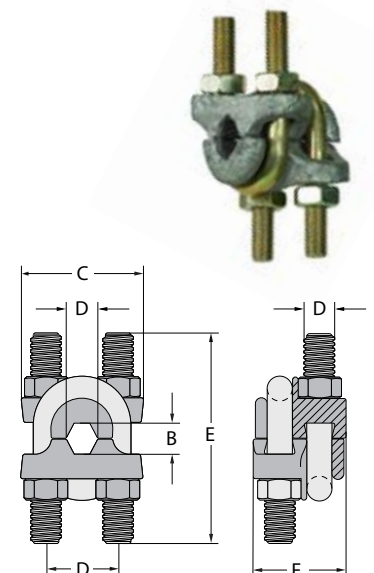

Australian Standard Wire Rope Grip

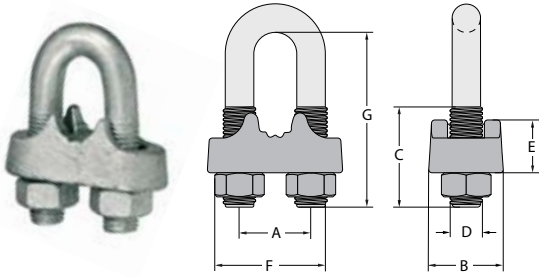

WARNING NOT FOR LIFTING PURPOSES

- Conforms to AS2076 and marked with AS and size under saddle.
- Heavy duty cast steel saddle and hi tensile U-bolt comes with larger nut size for greater tightening force.
- Sizes available are from 6mm to 52mm.
- Hot dipped galvanized finish on both U-bolt and saddle.
- **NOT FOR LIFTING PURPOSES.**

CODE	SIZE	Wt.	DIMENSIONS						
			A	B	C	D	E	F	G
	mm	kg/pc	mm	mm	mm	in	mm	mm	mm
301506	6	0.04	14	15	20	M6	12	28	26
301508	8	0.069	18	19	22	M8	14	34	32
301510	10	0.12	20	23	27	M10	17	42	40
301512	12	0.132	22.3	28	32	M10	20	50	48
301514	14	0.223	27	32	38	M12	22	52	52
301516	16	0.351	31	32	41	M14	26	66	64
301518	18	0.488	35	38	47	M16	27	68	68
301520	20	0.98	43	46	58	M20	36	89	88
301522	22	1.123	40	46	61	M20	32	72	92
301526	26	1.425	50	50	66	M22	38	90	96
301528	28	1.56	52	50	70	M22	39	92	104
301532	32	1.9	56	55	75	M24	41	112	120
301538	38	2.1	64	55	78	M24	48	120	122
301544	44	3.0	73	62	90	M27	52	135	150
301552	52	4.2	85	69	103	M30	56	154	185

Commercial Thimble



WARNING NOT FOR LIFTING PURPOSES

Commercial Thimbles are recommended for light duty applications.

- Zinc plated finish and made from light gauge steel.
- Sizes available are from 2mm to 25mm.
- Tolerances may vary for commercial products
- **NOT FOR LIFTING PURPOSES.**

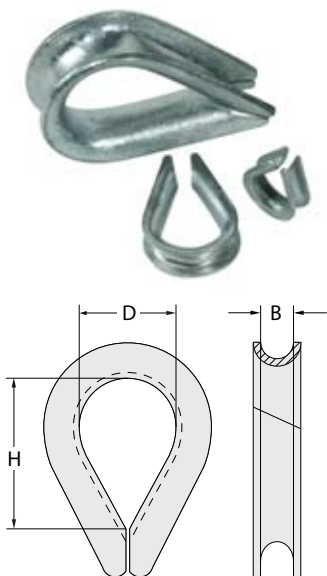

CODE	SIZE	Wt.	DIMENSIONS		
			B mm	H mm	D mm
	mm	kg/pc			
302002	2	0.002	2	10	8
302003	3	0.003	3	13	10
302004	4	0.006	4	16	11
302005	5	0.015	5	22	16
302006	6	0.018	6	26	19
302008	8	0.03	8	34	24
302010	10	0.043	10	42	32
302012	12	0.062	12	51	38
302016	16	0.105	16	60	42
302020	20	0.215	20	71	50
302022	22	0.34	22	79	62
302025	25	0.48	25	82	71

CODE	SIZE	Wt.	DIMENSIONS			
			A	B	H	D
	mm	kg/pc	mm	mm	mm	mm
302506	6	0.04	4	7	25	16
302508	8	0.052	5	7.9	33	22
302510	10	0.08	5	10.3	38	25
302511	11	0.09	6	12.7	41	29
302512	12	0.13	6	14.3	44	32
302514	14	0.15	7	15	46	38
302516	16	0.26	8	15.9	59	41
302518	18	0.35	8	18	65	46
302519	19	0.40	9	20.6	73	51
302520	20	0.50	10	21.6	75	52
302522	22	0.62	10	22.2	83	57
302524	24	0.9	11	25.4	92	64
302526	26	1.0	11	27	111	72
302528	28	1.1	12	28.6	111	76
302532	32	1.3	14	33.4	133	95
302536	36	2.2	16	38	152	105
302540	40	3.2	18	43	165	114
302544	44	5.6	20	47	178	127
302548	48	8.2	22	51	190	134
302552	52	11.0	22	55	203	140

AS Thimbles are recommended for heavy duty applications.

- Conforms to AS1138 and Gold tip painted the mark of Austlift products.
- Made from heat treated high tensile steel material.
- Sizes available are from 6mm to 52mm.
- Hot dipped galvanized finish.
- **FOR LIFTING PURPOSES.**

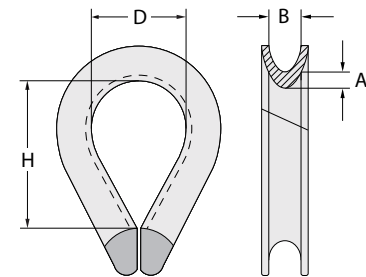
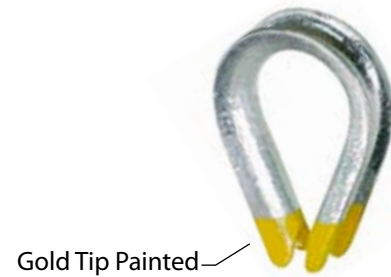

Thimble Eye Nut

Thimble Eynuts are recommended where a Wire Rope can be terminated to a female thread.

- Proof tested double the working load limit.
- Made from heat treated high tensile steel material.
- Thread sizes available are M20 and M24.
- Hot dipped galvanized finish.

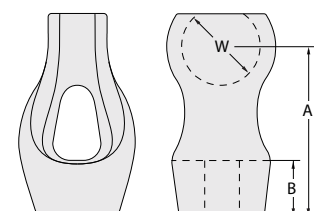

CODE	SIZE	WLL	MBS	DIMENSIONS		
				A	B	W
	mm	tonn	KN	mm	mm	mm
302720	M20	3.6	144	87	30	23
302724	M24	4.2	164	87	30	30

Solid Thimble Pilot Hole (Hot dip Gal)

Austlift Solid Heart Thimbles are commonly used to terminate Crane Ropes and are ideal where the Thimble is required to interface directly with a Rigging Screw, Turnbuckle or other rigging accessory where limited articulation is desired.

- Conforms to AS1138.
- Made from heat treated high tensile steel material.
- Sizes available are from 8mm to 48mm.
- Hot dipped galvanized finish.
- Refer to the Australian Standards for advice on drilling larger hole sizes.
- Pre-drilled pilot hole.
- FOR LIFTING PURPOSES.



Note: Holes sizes can be drilled to your requirements, charges apply.

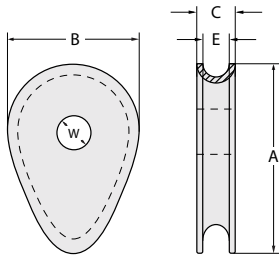

CODE	SIZE	DIMENSIONS				
		A	B	C	E	W
	mm	mm	mm	mm	mm	mm
302908	8	56	40	15	9	10
302910	10	70	50	17.5	11	10
302912	12	84	60	20	13	10
302914	14	98	70	23.5	16	10
302916	16	110	80	26	18	10
302918	18	130	90	28.5	20	10
302920	20	140	100	31	22	10
302922	22	150	110	33.5	24	10
302924	24	170	120	36	26	10
302926	26	180	130	39.5	29	10
302928	28	200	140	42	31	10
302932	32	220	160	47	35	10
302936	36	250	180	53	40	10
302940	40	280	200	58	44	10
302944	44	310	220	63	48	10
302948	48	POA				

Pre-drilled Solid Thimble

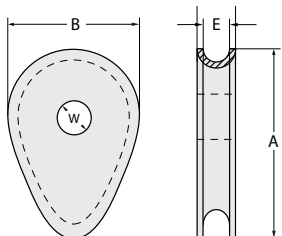

CODE	SIZE	PRE DRILLED Hole Size	DIMENSIONS				
			A	B	C	E	W
	mm		mm	mm	mm	mm	mm
302600	16	28mm	110	80	26	18	28
302605	18	30mm	130	90	28.5	20	31
302610	20	30mm	140	100	31	22	35
302615	22	32mm	150	110	33.5	24	38
302620	24	41mm	170	120	36	26	41
302625	26	44mm	180	130	39.5	29	44
302630	28	47mm	200	140	42	31	47
302635	32	53mm	220	160	47	35	53
302640	36	59mm	250	180	53	40	59
302645	40	65mm	280	200	58	44	65
302650	44	70mm	310	220	63	48	70

Austlift Open type Thimbles are for applications where a fitting may be placed into the Thimble without opening the Thimble and can be closed back to intended form.

- AS Thimbles are recommended for lifting applications.
- Conforms to AS1138 and Hot dipped galvanized finish.
- Made from heat treated high tensile steel material.
- Sizes available are from 10mm to 16mm.
- FOR LIFTING PURPOSES.

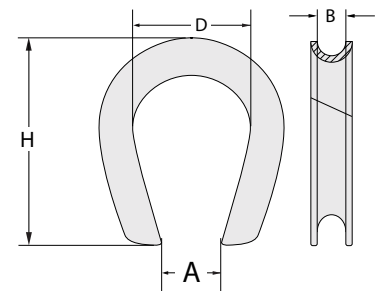

CODE	SIZE	Weight	DIMENSIONS			
	mm		A (mm)	B (mm)	D (mm)	H (mm)
302810	10	0.09	20	12	30	60
302812	12	0.13	20	16	37	65
302816	16	0.26	25	20	50	88

Wedged Socket, Open Type, Clevis

Austlift Open Wedge Socket is fitted to a Wire Rope. The nominal diameter of the Wire Rope shall be equal to the nominal size of the Wedge-Type Socket and the loaded end of the rope shall enter the Socket body so that when loaded it will not bend where it leaves the Socket body. Suitable for rope termination such as crane rope applications.

- Nominated rope sizes from 10mm to 24mm available.
- Manufactured from forged alloy steel material.
- Proof loaded 2 x WLL and Break tested to 5 x WLL.
- Complies to AS2740 with test certificate with each fitting.

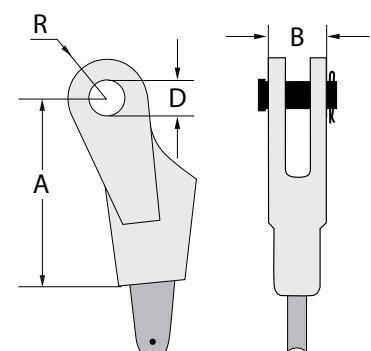

CODE	SIZE	WLL	Wt.	DIMENSIONS			
	mm	Tonne	kg/pc	A mm	B mm	D mm	R in
308010	10	1.5	1	120	38	20	25
308012	12	2	1.7	155	44	25	30
308014	14	2.5	2.34	185	51	30	35
308016	16	3	3.27	195	60	34	42
308018	18	3.5	4	195	64	36	44
308020	20	5.1	5.45	220	72	38	50
308022	22	5.6	6.37	240	76	40	52
308024	24	6.6	8.32	260	83	50	60

Copper Ferrules

Austlift Copper type Ferrules made to DIN standard and mainly used for splicing Stainless Steel Wire Rope to form an eye for Wire Rope Slings, Winch cable etc.

- High quality Ferrules and conforms to DIN 3039.
- Copper hydraulic machine press type.
- Sizes from 1.5mm to 16mm.
- For turn-back Wire Rope splicing.
- Stamped with identification mark and size from 8mm onwards.

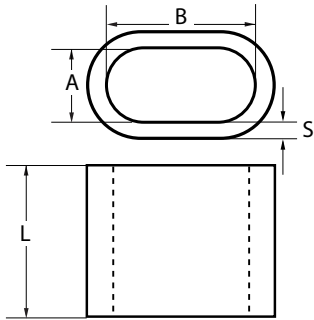

PRODUCT CODE	DIN CODE	DIMENSIONS			
		A (mm)	B (mm)	S (mm)	L (mm)
304015	1.5	1.8	3.6	1.05	6
304020	2	2.4	4.8	0.85	7
304025	2.5	2.7	5.4	1.1	9
304030	3	3.3	6.6	1.35	11
304035	3.5	3.9	7.8	1.6	13
304040	4	4.3	8.8	1.7	14
304050	5	5.6	11.2	2.1	18
304060	6	6.7	13.4	2.5	21
304065	6.5	6.9	14	2.7	23
304080	8	8.5	17	3.5	28
304090	9	9.9	19.8	3.7	32
304100	10	10.9	21.8	4.1	35
304120	12	13.2	26.4	4.9	42
304140	14	15.3	30.6	5.8	49
304160	16	17.5	35	6.7	56

Nickel Plated Copper Ferrules

(Hand Swaged)

Austlift Copper type hand pressed Ferrules made to DIN standard and mainly used for splicing Stainless Steel Wire Rope to form an eye for Wire Rope Slings, Balustrade etc.

- High quality Ferrules and conforms to DIN 3039.
- Hand pressed type with use of crimping tool.
- Sizes from 1.5mm to 4mm.
- For turn-back Wire Rope splicing.
- Nickel plated to match rope colour .

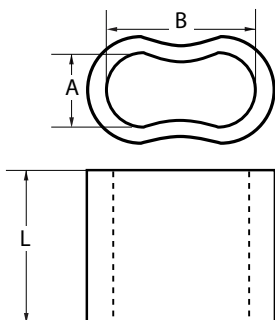
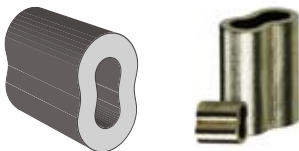

CODE	SIZE mm	DIMENSIONS		
		A (mm)	B (mm)	L (mm)
305015	1.5	1.5	4.9	8
305020	2	2	4.9	9
305025	2.5	2.5	6	10
305030	3	3	7.3	13
305035	3.5	3.5	8	14
305040	4	4	9.1	16

Note: Please confirm upon order re-applied Wire Rope, as Ferrule sizes differ for FC & IWRC Wire Rope during swaging

PRODUCT CODE	DIN CODE	DIMENSIONS				N,W (kg) PER 1000 PCS
		A (mm)	B (mm)	S (mm)	L (mm)	
303015	1.5	1.7	3.4	0.75	6	0.211
303020	2	2.2	4.4	0.85	7	0.375
303025	2.5	2.7	5.4	1.05	9	0.499
303030	3	3.3	6.6	1.25	11	0.843
303035	3.5	3.8	7.6	1.5	13	1.32
303040	4	4.4	8.8	1.7	14	1.81
303045	4.5	4.9	9.8	1.9	16	2.61
303050	5	5.5	11	2.1	18	3.57
303060	6	6.6	13.2	2.5	21	5.86
303065	6.5	7.2	14.4	2.7	23	7.55
303080	8	8.8	17.6	3.3	28	13.7
303090	9	9.9	19.8	3.7	32	19.8
303100	10	10.9	21.8	4.1	35	26.4
303110	11	12.1	24.2	4.5	39	35.8
303120	12	13.2	26.4	4.9	42	45.8
303130	13	14.2	28.4	5.4	46	59.7
303140	14	15.3	30.6	5.8	49	73.5
303160	16	17.5	35	6.7	56	111
303180	18	19.6	39.2	7.6	63	156
303200	20	21.7	43.4	8.4	70	217
303220	22	24.3	48.6	9.2	77	292
303240	24	26.4	52.8	10	84	376
303260	26	28.5	57	10.9	91	481
303280	28	31	62	11.7	98	603
303300	30	33.1	66.2	12.5	105	739
303320	32	35.2	70.4	13.4	112	897
303340	34	37.8	75.6	14.2	119	1077
303360	36	39.8	79.6	15	126	1275
303380	38	41.9	83.8	15.8	133	1503
303400	40	44	88	16.6	140	1734
303420	42	46.2	92.4	17.5	147	2024
303440	44	48.4	96.8	18.3	154	2314
303460	46	50.6	101.2	19.2	161	2662
303480	48	52.8	105.6	20	168	3010
303520	52	57.2	114	21.6	182	3813
303540	54	59.4	118	22.5	189	4293

Austlift Aluminum type Ferrules made to DIN standard and mainly used for splicing steel Wire Rope to form an eye for Wire Rope Slings, Winch Cable etc.

- High quality Ferrules and conforms to DIN 3039.
- Aluminum hydraulic machine press type.
- Sizes from 1.5mm to 54mm.
- For turn-back Wire Rope splicing.
- Stamped with identification mark and size from 8mm onwards.

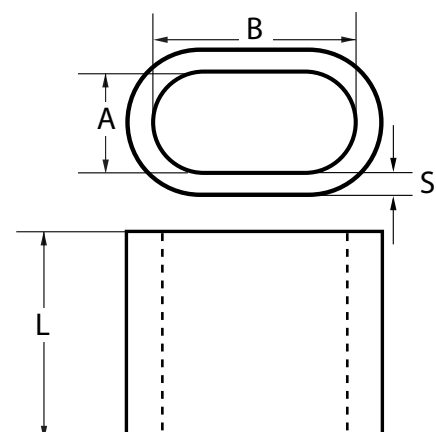

WARNING



- Failure to read, understand, and follow these instructions may cause death or serious injury.
- Read and understand these instructions before using Ferrules.
- Match the same size Ferrules to the same size Wire Rope as per chart below.
- Do not use with plastic coated Wire Rope. Strip plastic coating before assembly.

FERRULES SELECTION CHART

Wire Rope			Case1	Case2	Case3
Nominal diameter mm	Measured from to mm		Single layer round strand with fibre core & cable laid rope.	Single layer round strand ropes with wire core & non-rotating rope	Single layer round strand ropes with wire core non-rotating rope & parallel closed rope.
	mm	mm			
2.5	2.5	2.7	2.5	3	-
3	2.8	3.2	3	3.5	-
3.5	3.3	3.7	3.5	4	-
4	3.8	4.3	4	4.5	-
4.4	4.4	4.8	4.5	5	-
5	4.9	5.4	5	6	-
6	5.5	5.9	6	6.5	-
6	6	6.4	6	6.5	7
6.5	6.5	6.9	6.5	7	8
7	7	7.4	7	8	9
8	7.5	7.9	8	9	9
8	8	8.4	8	9	10
9	8.5	8.9	9	10	10
9	9	9.5	9	10	11
10	9.6	9.9	10	11	11
10	10	10.5	10	11	12
11	10.6	10.9	11	12	12
11	11	11.6	11	12	13
12	11.7	11.9	12	13	13
12	12	12.6	12	13	14
13	12.7	12.9	13	14	14
13	13	13.7	13	14	16
14	13.8	13.9	14	16	16
14	14	14.7	14	16	18
16	14.8	15.9	16	18	18
16	16	16.8	16	18	20
18	16.9	17.9	18	20	20
18	18	18.9	18	20	22
20	19	19.9	20	22	22
20	20	21	20	22	24
22	21.1	21.9	22	24	24
22	22	23.1	22	24	26
24	23.2	23.9	24	26	26
24	24	25.2	24	26	28

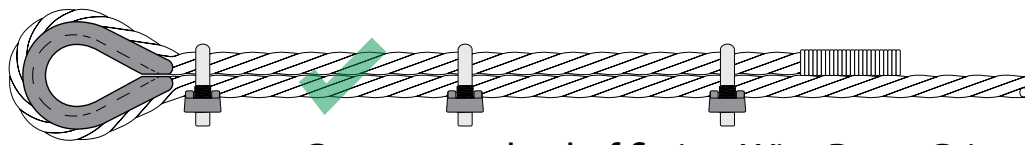

Correct method of fitting Wire Rope Grips

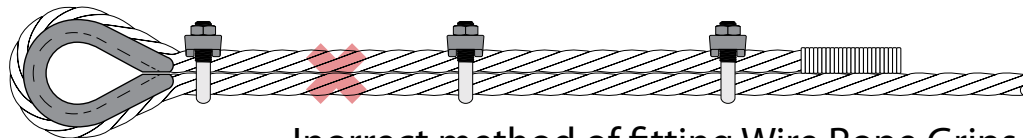

Inorrect method of fitting Wire Rope Grips

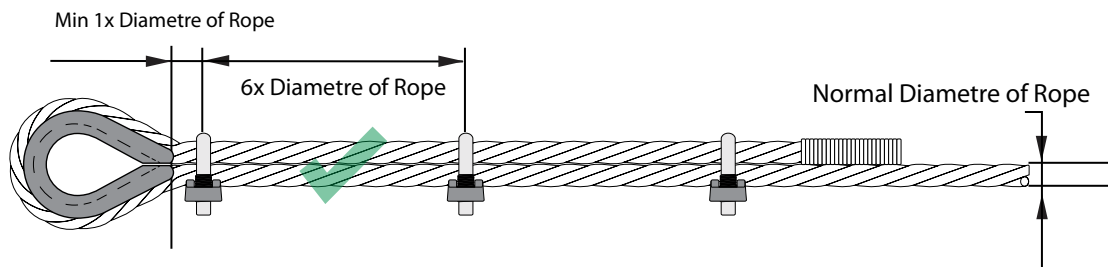

ATTACHMENT OF WIRE-ROPE GRIPS

Nominal size of wire-rope grip (mm)	Nominal size of thread of bolt or stud(mm)	Minimum number of wire-rope grips	Tightening torque N.m
8	8	3	6
10	10	3	16
12	12	3	24
14	12	4	35
16	16	4	50
18	16	4	65
22	16	4	100
26	20	5	135
28	20	5	160
32	20	6	210
36	24	6	275
40	24	6	365
44	28	8	See Note 2
52	32	8	
56	32	8	
60	32	9	
64	32	9	
70	32	10	
75	38	10	

ATTACHMENT OF WIRE-ROPE GRIPS

Refer to Table 1 in following these instructions. Turn back specified amount of rope from Thimble or loop. Apply first clip one base width from dead end of rope. Apply U-Bolt over dead end of Wire Rope – live end rests in saddle (Never saddle a dead horse!) Use torque wrench to tighten evenly, alternate from one nut to the other until reaching the recommended torque

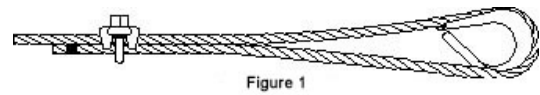

Figure 1

When two clips are required, apply the second clip as near the loop or Thimble as possible. Use torque wrench to tighten evenly, alternating until reaching the recommended torque. When more than two clips are required, apply the second clip as near the loop or Thimble as possible, turn nuts on second clip firmly, but do not tighten. Proceed to Step 3



Figure 2

When three or more clips are required, space additional clips equally between first two - take up rope slack - use torque wrench to tighten on each U-Bolt evenly, alternating from one nut to the other until reaching recommended torque.



Figure 3

The preferred method of splicing two Wire Ropes together is to use interlocking turn back eyes with Thimbles, using the recommended number of clips on each eye (See Figure 5).



Figure 5

An alternate method is to use twice the number of clips as used for a turn back termination. The rope ends are placed parallel to each other, overlapping by twice the turn back amount shown in the application instructions. The minimum number of clips should be installed on each dead end (See Figure 6). Spacing, installation torque, and other instructions still apply

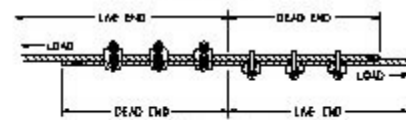

Figure 6

IMPORTANT

Apply first load to test the assembly. This load should be of equal or greater weight than loads expected in use. Next, check and use torque wrench to retighten to recommended torque. In accordance with good rigging and maintenance practices, the Wire Rope end termination should be inspected periodically for wear, abuse, and general adequacy.

WEDGED SOCKET INFORMATION



Incorrect methods for fitting Wedge Sockets to Wire Ropes

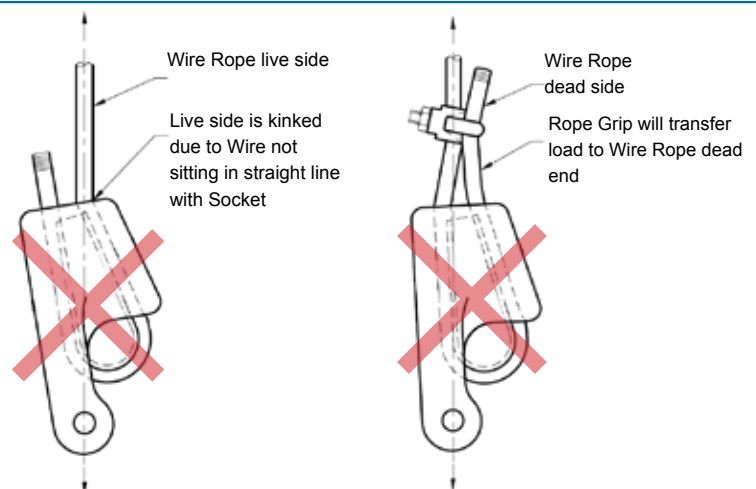

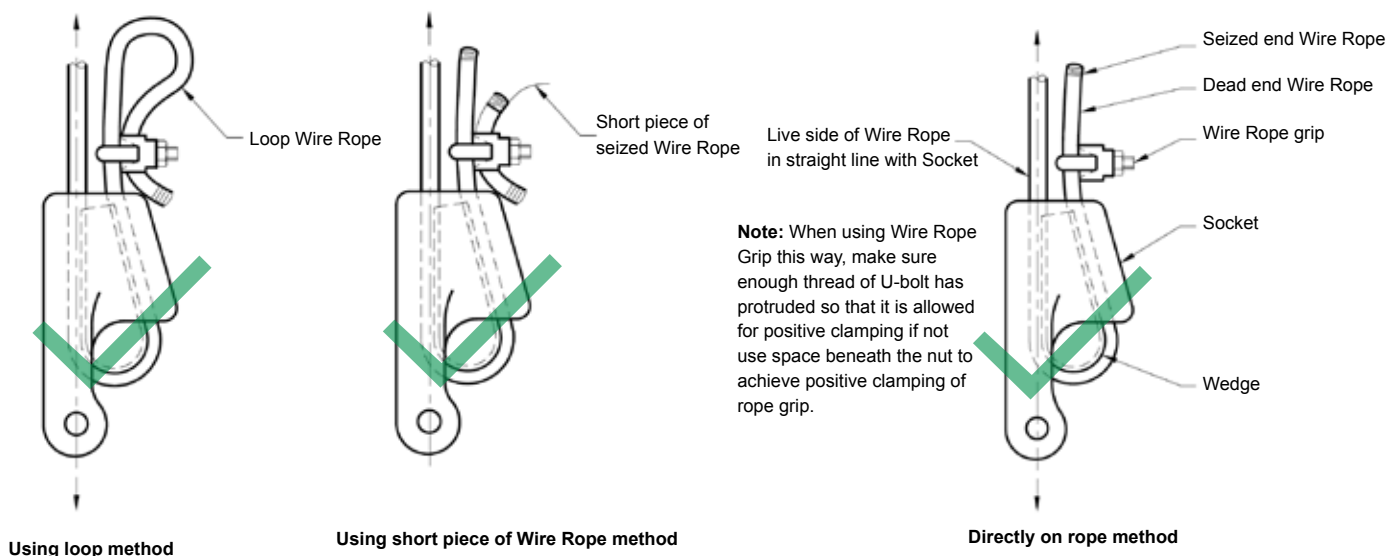
Safety Information For Wedge Socket
Inspection/Maintenance Safety

- Always inspect Socket, Wedge and Pin before operation.
- Do not use part if displaying cracks, nicks or gouges or any other visible damage.
- Do not use modified or substitute parts. Only use Austlift genuine parts.
- Repair minor nicks or gouges to Socket or Pin by lightly filling until surfaces are smooth.
- Do not reduce original dimension more than 10%. Do not repair by welding any part of Wedge Socket.
- Inspect permanent assemblies periodically, or more often in severe operating conditions.
- Do not mix and match Wedges or Pins between models or sizes always use the same brands.
- Always select the proper Wedge and Socket for the Wire Rope size.

Operating Safety

- Apply first load to fully seat the Wedge and Wire Rope in the Socket, ensure the load is equal or greater weight than loads expected in use.
- Efficiency rating of the Wedge Socket termination is based upon the catalog breaking strength of Wire Rope. The efficiency of a properly assembled Wedge Socket is 80%.
- During use, do not damage the dead end section with any other elements of the rigging equipment.



- Loads may slip or fall if the Wedge Socket is not properly installed.
- A falling load can seriously injure or kill personnel.
- Read and understand these instructions before installing the Wedge Socket.
- Do not side load the Wedge Socket in any way.
- Apply first load to fully seat the Wedge and Wire Rope in the Socket. This load should be of equal or greater weight than loads expected in use.

SYDNEY

43 Frank Street Wetherill Park, NSW 2164
T. 02 9757 2277 F. 02 9757 2922

MELBOURNE

47 Technology Drive, Sunshine West VIC 3020
T. 03 9314 5525 F. 03 9314 5526

PERTH

58A Tulloch Way Canning Vale, WA 6155
T. 08 9256 3440 F. 08 9256 4408

BRISBANE

7 Durbell St Acacia Ridge, QLD 4110
T. 07 3272 0777 F. 07 3272 0788

www.austlift.com.au